

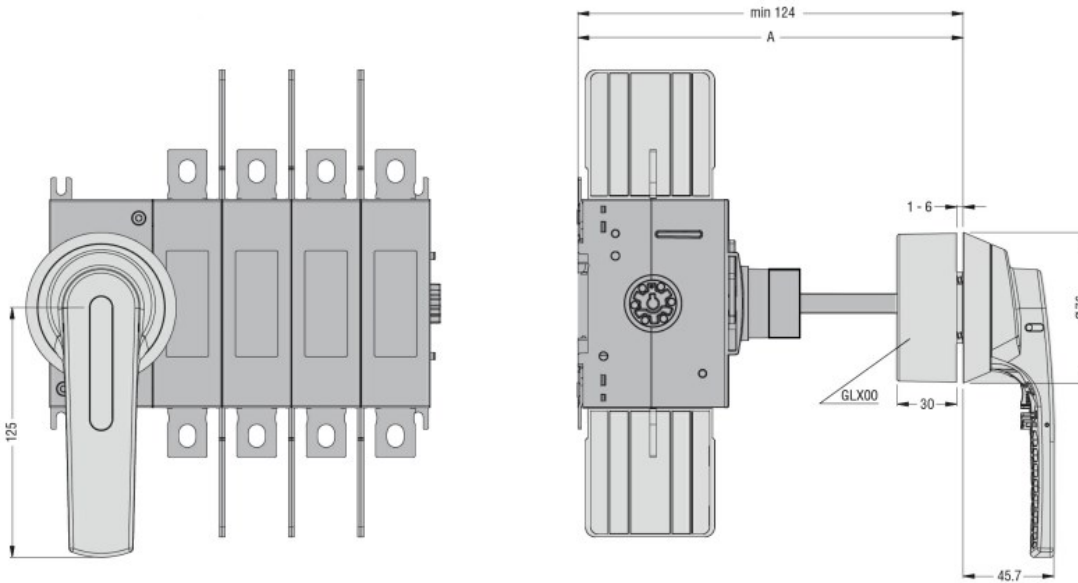

Dimensions

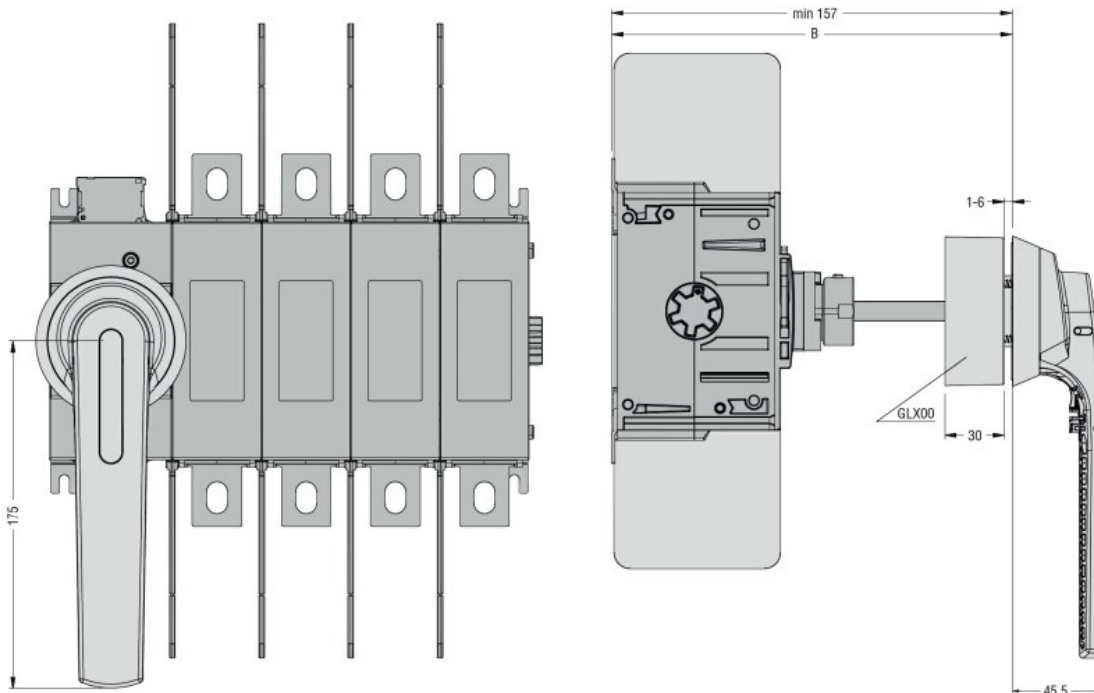

GLX7...S10	A [mm]	
	min	max
GLX7150S10	124...	194
GLX7200S10	124...	244
GLX7300S10	124...	344
GLX7400S10	124...	444
GLX7500S10	124...	544



GLX7...S10	B [mm]	
	min	max
GLX7150S10	157...	227
GLX7200S10	157...	277
GLX7300S10	157...	377
GLX7400S10	157...	477
GLX7500S10	157...	577

Certifications and compliance

Compliance

IEC/EN 60947-1

IEC/EN 60947-3

Certifications

cULus
EAC

ETIM classification

ETIM 8.0

EC002498 -
Accessories/spare
parts for low-
voltage switch
technology